

CAD FILE:

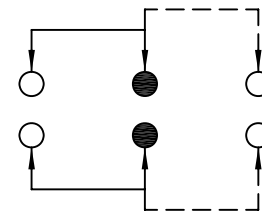

SCHEMATIC (NON-SHORTING)

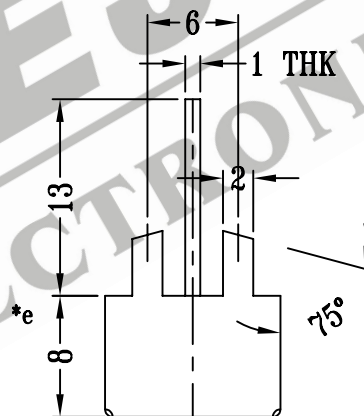
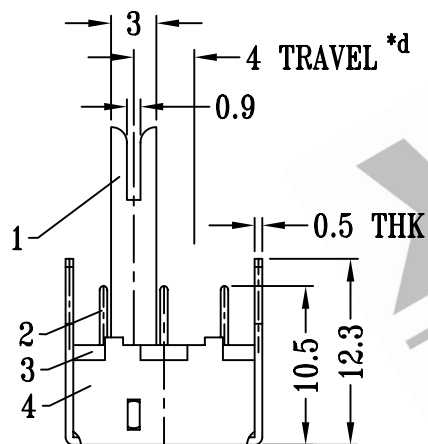
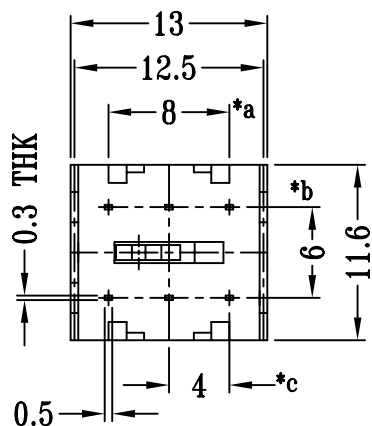
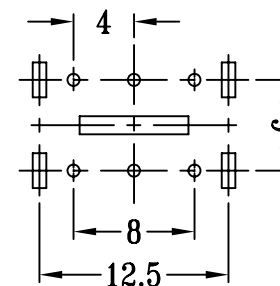

P.C.B LAYOUT

注:带"*"表示关键尺寸(5个)

8	KNOB	POM	1	BLACK	TOLERANCE UNLESS SPECIFIED	SHENZHEN XIEJIA ELECTRONICS CO.,LTD.				
7	STEEL BALL	STEEL	2	NATURAL						
6	SPRING	STEEL WIRE	1	TEMPER	WITHIN : 1.5±0.1mm	ISSUE	DATE	DESCRIPTIONS		APPD.
5	CONTACT CLIP	PBS	2	Ag CLAD	OVER : 1.5±0.2mm					
4	FRAME	STEEL STRIP	1	Zn PLATED	TITLE : BOTTOM SLIDE SWITCH		UNIT : MM	DRWG NO.: XJ-DR-BK22H13-00		
3	BASE	PHENOLIC RESIN	1	NATURAL	MODEL: BK-22H13		SCALE: 2 : 1	DWN.	ZHOUYU	2002-4-9
2	TERMINAL	BRASS STRIP	6	Ag PLATED OVER Ni PLATED	ALL MATERIALS MUST BE COMPLIANT TO ROHS			CHK'D	FANGYING	2002-4-9
1	STEEL KNOB	STEEL STRIP	1	Ni PLATED				APPD.	KANGXINAN	2002-4-9
NO.	PART NAME	MATERIAL	Q'TY	FINISHING						